

SVD meeting, Vienna,
June 11, 2001

VA1, VA1TA testing for single event effects

Peter Križan and Samo Korpar (Ljubljana)

- Single event effect testing with lasers
- Test set-up
- Status and plans

Single event effects

- single event upset (SEU)
- single event latch-up (SELU)

SELU symptoms were observed in SVD1.

Not clear, how to extrapolate to 0.35 μm , and to the VA1TA with more on-chip logic.

SEE testing with lasers

Relate hadron induced effects to laser pulses

- several studies have involved laser beams to pin down the positions of problematic elements (low threshold) in the chip (→ table)
- a good correlation was found of thresholds determined in heavy ion and laser induced SEE (→ plot)
- a typical low threshold element has a threshold at about 1-10 pJ

Questions

- are all the chip elements fully accessible to laser light (metal layers)
- how to normalize to the experimental environment

Several papers on the subject, e.g. D. McMorrow et al., IEEE TNS **47** (2000) 559.

Relation between the SEE threshold in heavy ion beams and with laser pulses.

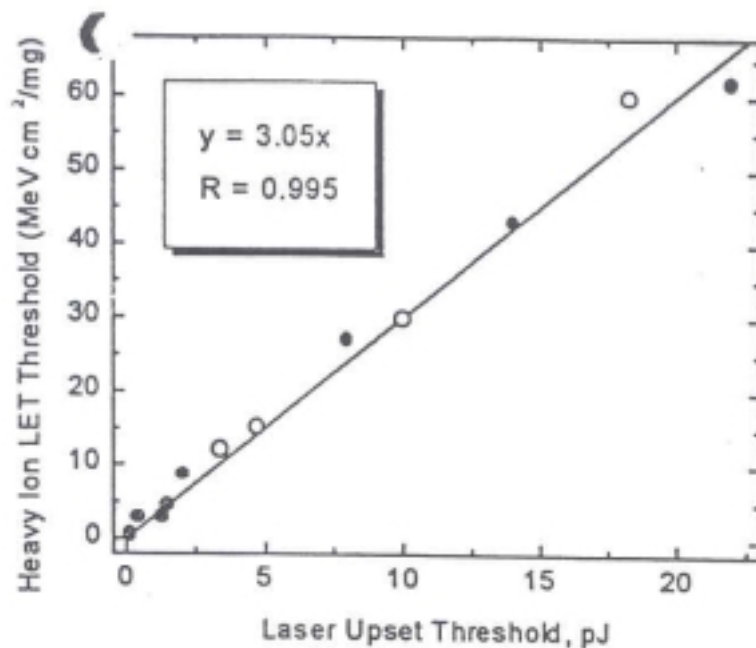

Figure 5. Measured heavy ion SEU and SEL LET thresholds plotted against the measured laser upset threshold for data for 13 cases listed in Table 3.

Table 3 – Pulsed Laser and Heavy Ion Upset Threshold Data

Part Description	Test	Laser SEE Threshold (pJ)	Equivalent Laser LET (MeV·cm ² /mg)	HI LET Threshold (MeV·cm ² /mg)	HI LET Uncertainty (MeV·cm ² /mg)	References
GaAs SRAM	SEU	0.15	0.45	0.7	<0.8	7, 13
AMD 93L422	SEU	0.14	0.42	0.47	<0.5	7, 14
HM65162	SEU	0.43	1.3	3	3-4.5	10, 15
HM65162	SEL	1.5	4.5	4.5	3.3-4.5	10, 16
RDC19220	SEU	1.3	3.9	3	3.3-5.5	9
RDC19220	SEL	2.8	8.4	-	5.5-15	9
AD2S80	SEU	2.1	6.2	9	5.5-15	9
LM TS-A	SEU	3.4	10	12	8-12	this work
LM TS-B	SEU	4.7	14	15	12-15	this work
LM TS-C	SEU	10	30	30	26.5-30	this work
LM TS-D	SEU	18.3	55	60	50-60	this work
CMOS TS-5	SEL	8	24	27	18-27	3
CMOS TS-6	SEL	14	42	43	41-43	3
CMOS TS-7	SEL	22	66	62	53-62	3
CMOS TS-9	SEL	33	99	111	102-111	3

Test set-up in Ljubljana

Goals:

- set up a test stand for VA1/VA1TA read-out chips with VA-DAQ and a PC with full LabView software
- test with medium strong laser close to expected SEE threshold, 2d scan over the chip surface
- test with a strong laser: vary intensity, 2d scan
- normalisation to Belle environment: in the same test set-up compare VA1/VA1TA with VA (known SEE rate in Belle)

People involved

- Belle: S. Korpar, P. Križan (+ B. Golob, M. Starič)
- laser and optical system: M. Zavrtanik
- VA/TA read-out: A. Studen (Compton Camera)
- high power laser: help from the solid state lab

Test set-up: components

- VA-DAQ system
- PC with full development LabView system
- 2d computer steerable table
- laser
- optical system for focusing
- optical bench

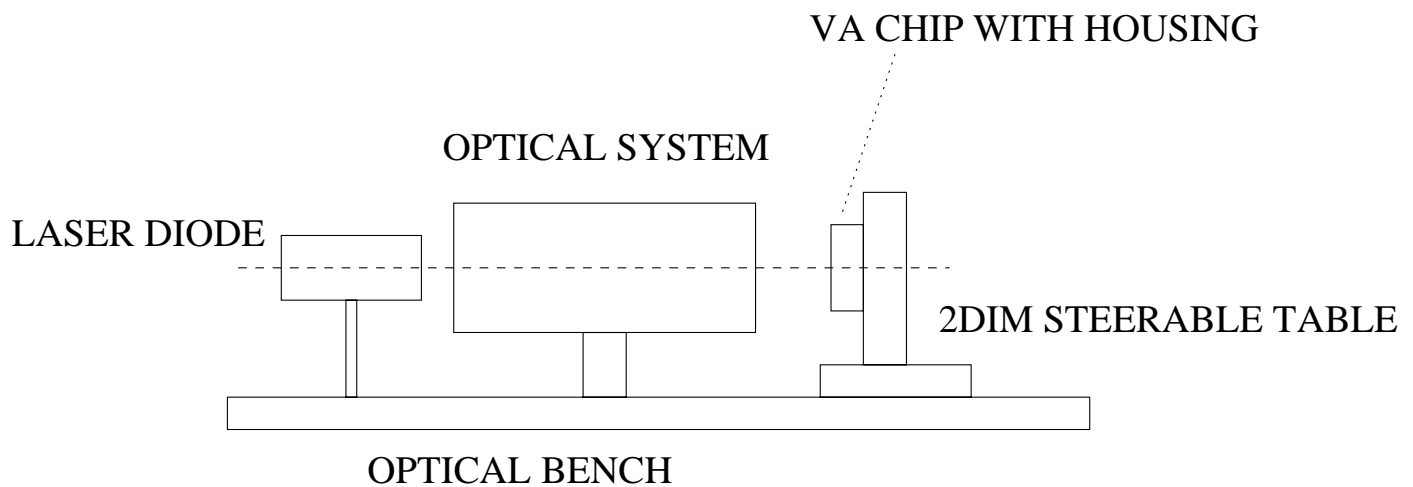

Lasers with optical system

Medium power

- laser diode (triggerable, pulse width ≈ 1 ns, pulse energy a few pJ)
- laser diode is an astigmatic source (divergence 8×29 degrees FWHM) \rightarrow needs an optical system to arrive at a circular spot of μm size \rightarrow slide
- optical system: collimator, astigmatic corrector, beam expander, focusing system \rightarrow slide
- expected focus spot size: width $1.5 \mu\text{m}$ (FWHM), depth $2 \mu\text{m}$ (FWHM)

High power

- sapphire-Ti laser, $\lambda = 850$ nm
- 0.1 ps pulse width, 10 nJ pulse energy at 80 MHz pulse frequency, more energy/pulse at lower pulse frequency (needed anyway)
- system of attenuators to tune the pulse power
- in the solid physics department, get shared beam time, move 2d table with chip, and the VADAQ + notebook

Optical system

- collimator (Melles-Griot 06 GLC 003)
- anamorphic prism pair (Melles-Griot 06 GPA 004)
- beam expander (Melles-Griot 06 GBF 001)
- focussing system (Melles-Griot 06 GLR 001)

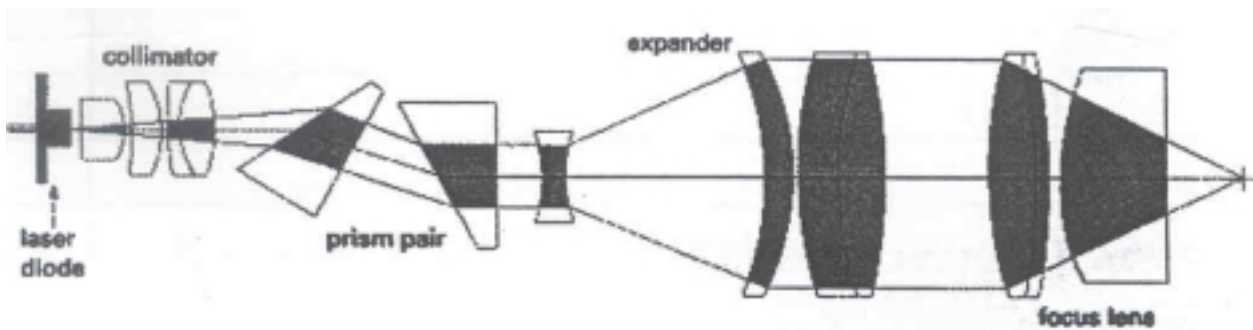

Status and plans

Status

- VA-DAQ system with PC: delivered (Dan Marlow), tested
- VATA chip for the Compton camera project: powered, read-out seems to work OK
- VA1Prime chip: delivered (IDEAS), mounted, powered, problems in read-out (→ to be discussed with experts)
- laser diode + triggered power supply: assembled
- 2d table, optical bench: ordered
- optical system: ordered, delivery expected in two weeks

Plans

- get used to the VADAQ system (test modes, patterns, use of trigger from the laser supply)
- test with laser diode and manually driven sample table
- assemble the optical bench and comput. cont. 2d table + software

Plans - continued

- 2d scan the VA1Prime
- 2d scan the (to be) delivered VA1, VA1TA
- move 2d table with chip, and the VADAQ + notebook to the high power laser in the solid state lab
- evaluate the results in terms of expected SEE rates in the Belle environment