

Global Muon Trigger Update

A 3D cutaway rendering of the CMS muon detector, showing the complex arrangement of muon chambers and support structures. The detector is composed of several layers of muon chambers, each with a different color (red, yellow, blue, purple) to distinguish between different regions. The chambers are arranged in a cylindrical shape around the central interaction point.

H. Sakulin¹⁾, A. Taurok²⁾, N. Neumeister³⁾

1) CERN / EP

2) HEPHY Vienna

3) CERN / EP (on leave from HEPHY Vienna)

Trigger Meeting, CMS Week,
September 27th, 2000



CMS Muon Trigger System

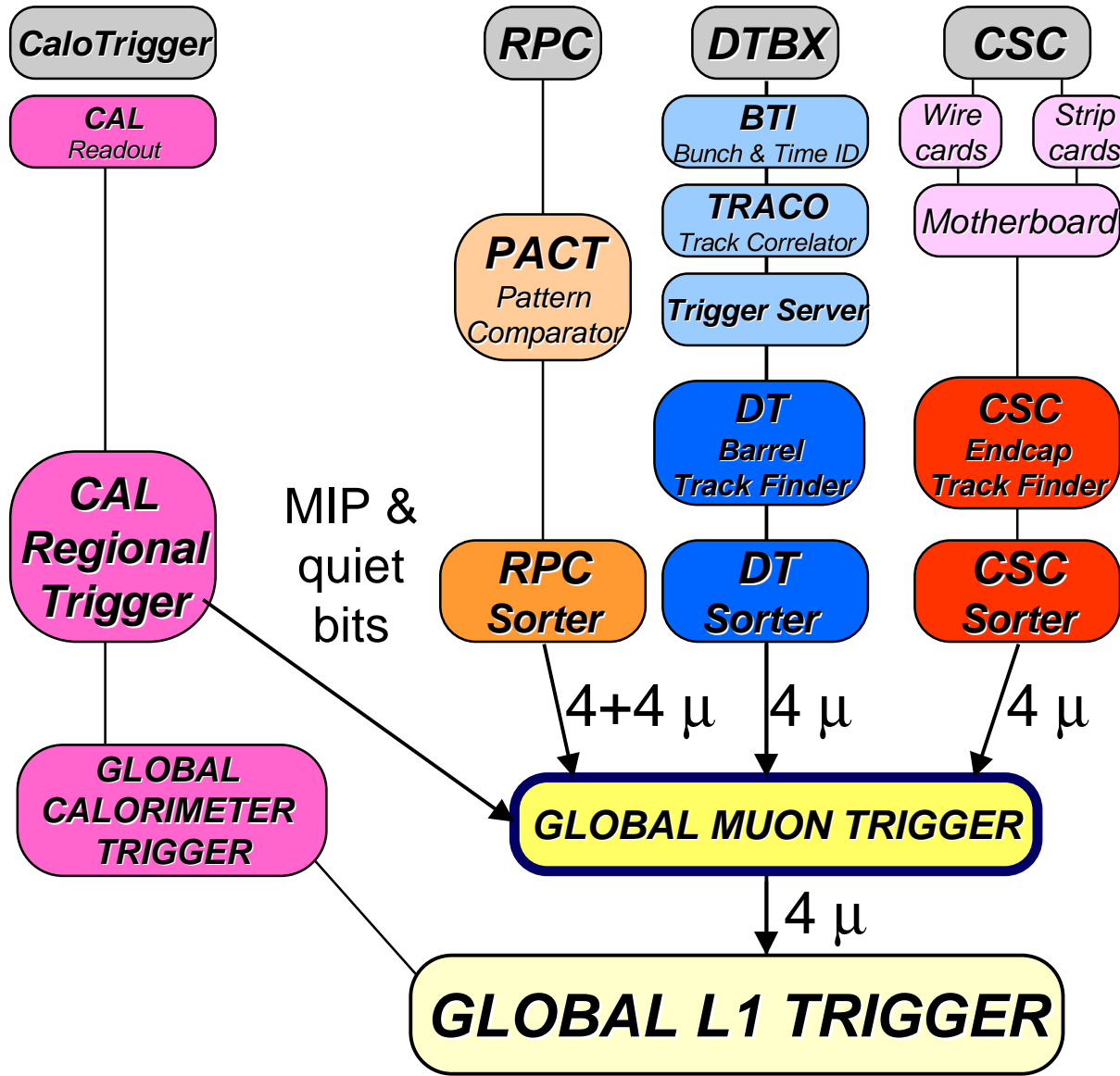

Global Muon Trigger



Goals of GMT



- Make use of the Complementarity of RPC and DT/CSC Trigger
- Increase Efficiency
- Reduce Ghosts
- Get best performance in p_T -measurement

Strategy

- Match in parallel brRPC/DT and fwdRPC/CSC candidates
- If match found, merge muon parameters and forward
- If unmatched muon remains, forward based on quality criteria
 - quality criteria can depend on detector type,
(to some extent) pseudorapidity and p_T
- Sort muons by rank and forward best 4 muons of whole detector to Global Trigger



Muon Matching, Pairing and Merging



- Calculate match quality function based on proximity in space ($\Delta\eta$ and $\Delta\phi$)

$$match_quality \propto \frac{1}{\sqrt{w_A \cdot (\Delta\eta)^2 + w_B \cdot (\Delta\phi)^2}}$$

- Find maximum in row and column
- Fill Pair Matrix

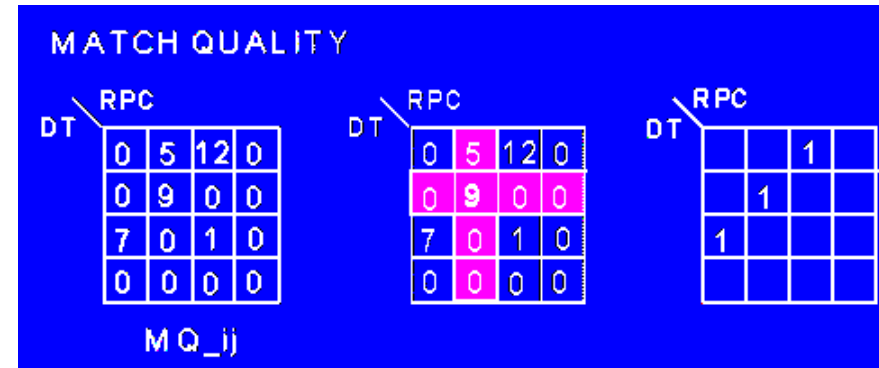

- In parallel calculate Single Rank based on p_T , Quality, η , ϕ
- Muon Merger Logic merges paired candidates (3 possible options):

- winner/looser implementation: forward only candidate with higher rank
- parameter selection implementation: select each parameter either from DT/CSC system or from RPC system
- parameter mixing implementation: parameters can be mixed. E.g. average of the two p_T measurements

Under study



GMT Hardware

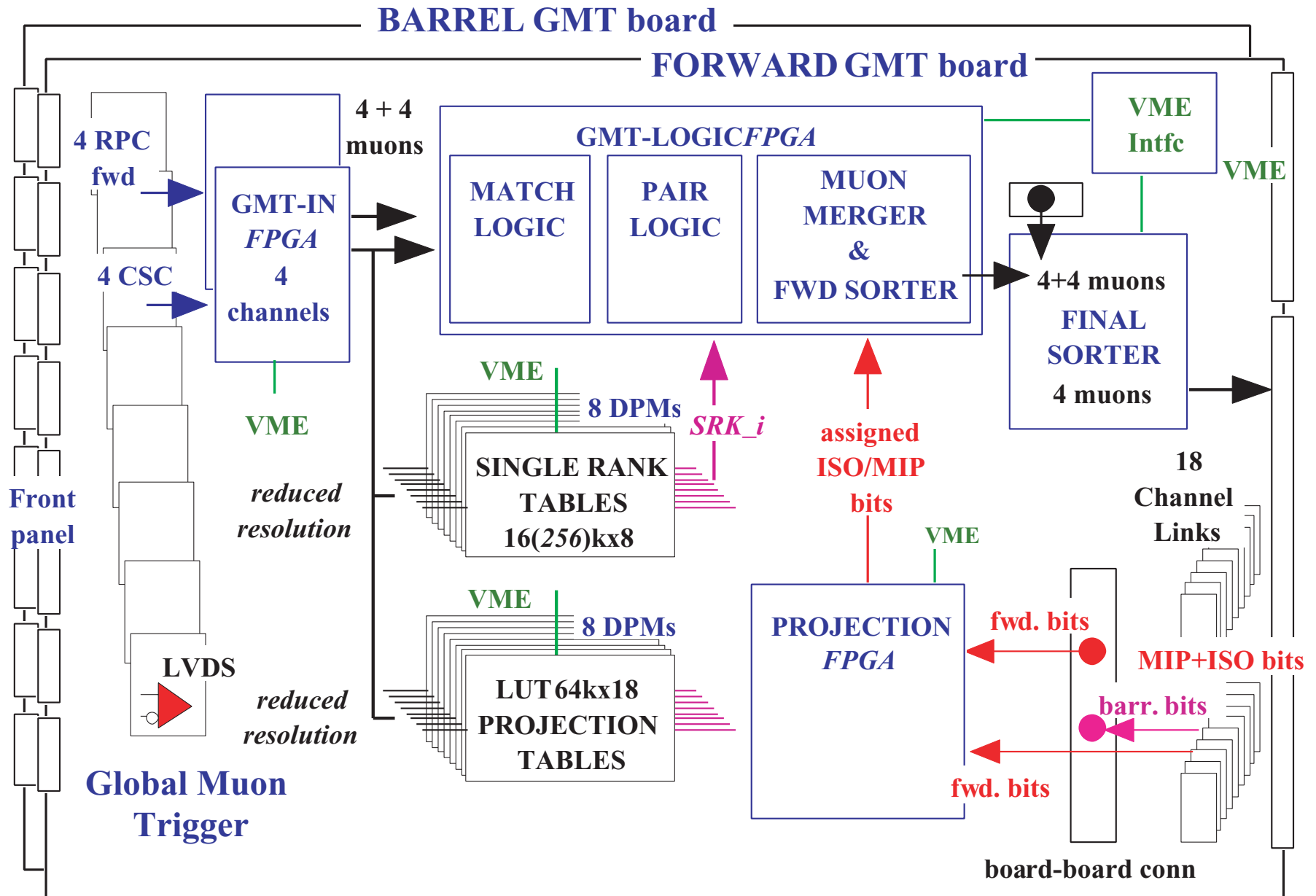



GMT Latency

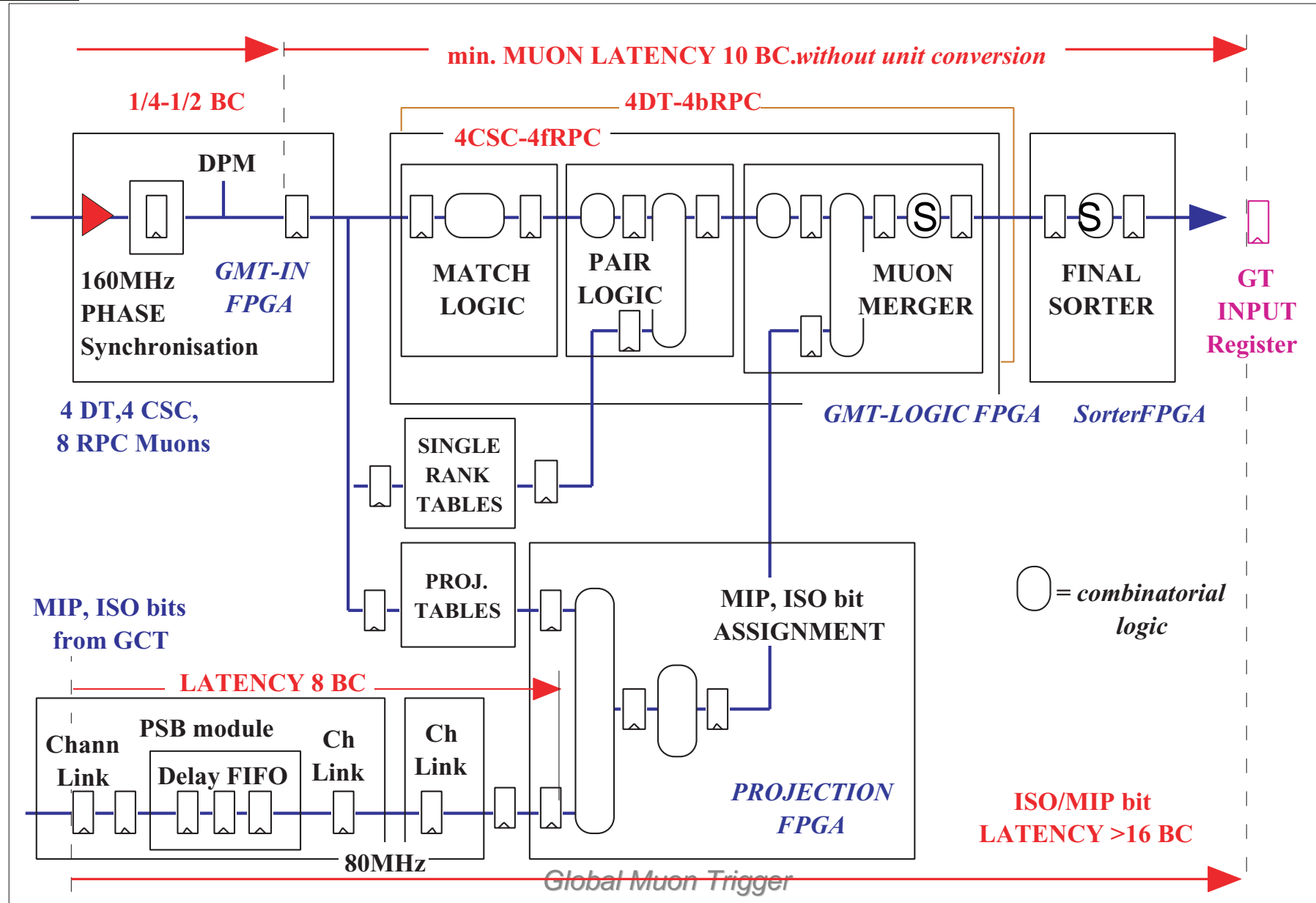



Simulation



- Whole detector (including overlap region) now simulated in ORCA
- Agreement on same p_T -scale and 90% p_T -definition in all sub-systems
- *Preliminary Results with ORCA 4.3.0 pre4*
 - *DT code with new p_T scale and definition*
 - *RPC code with new p_T scale*
 - *CSC code from 30.Aug 2000*
 - Awaiting update of CSC simulation
 - *GMT in winner/loser implementation*

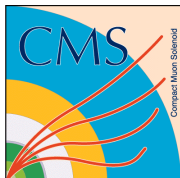

Efficiency vs. η (ORCA 4)

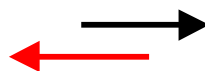

$|\eta_{DT}| > 0.91$, $|\eta_{CSC}| < 1.06$
match with RPC required

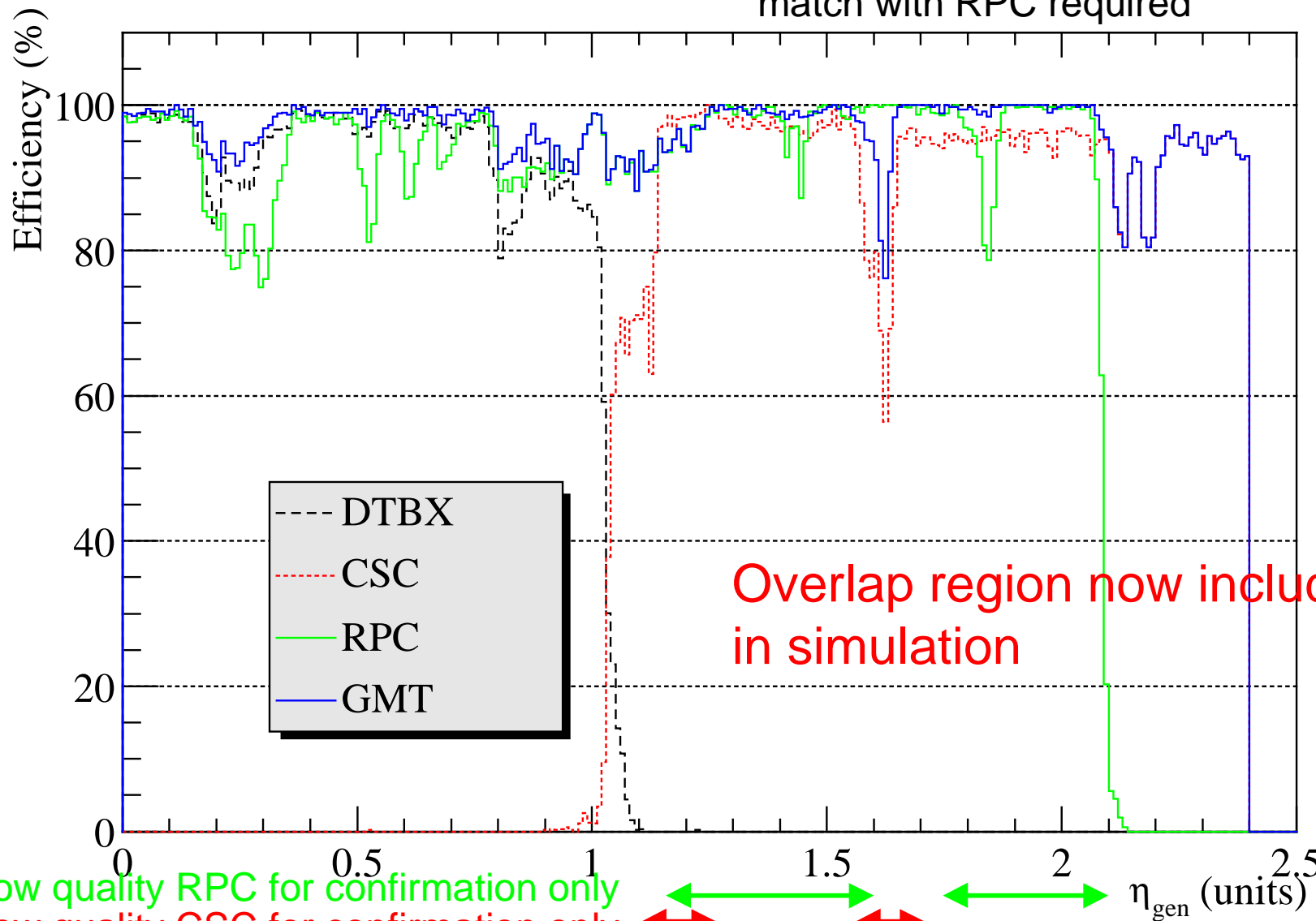

Low quality RPC for confirmation only
Low quality CSC for confirmation only



η_{gen} (units)

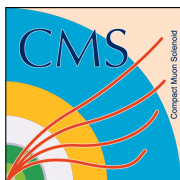

Ghosts vs. η (ORCA 4)

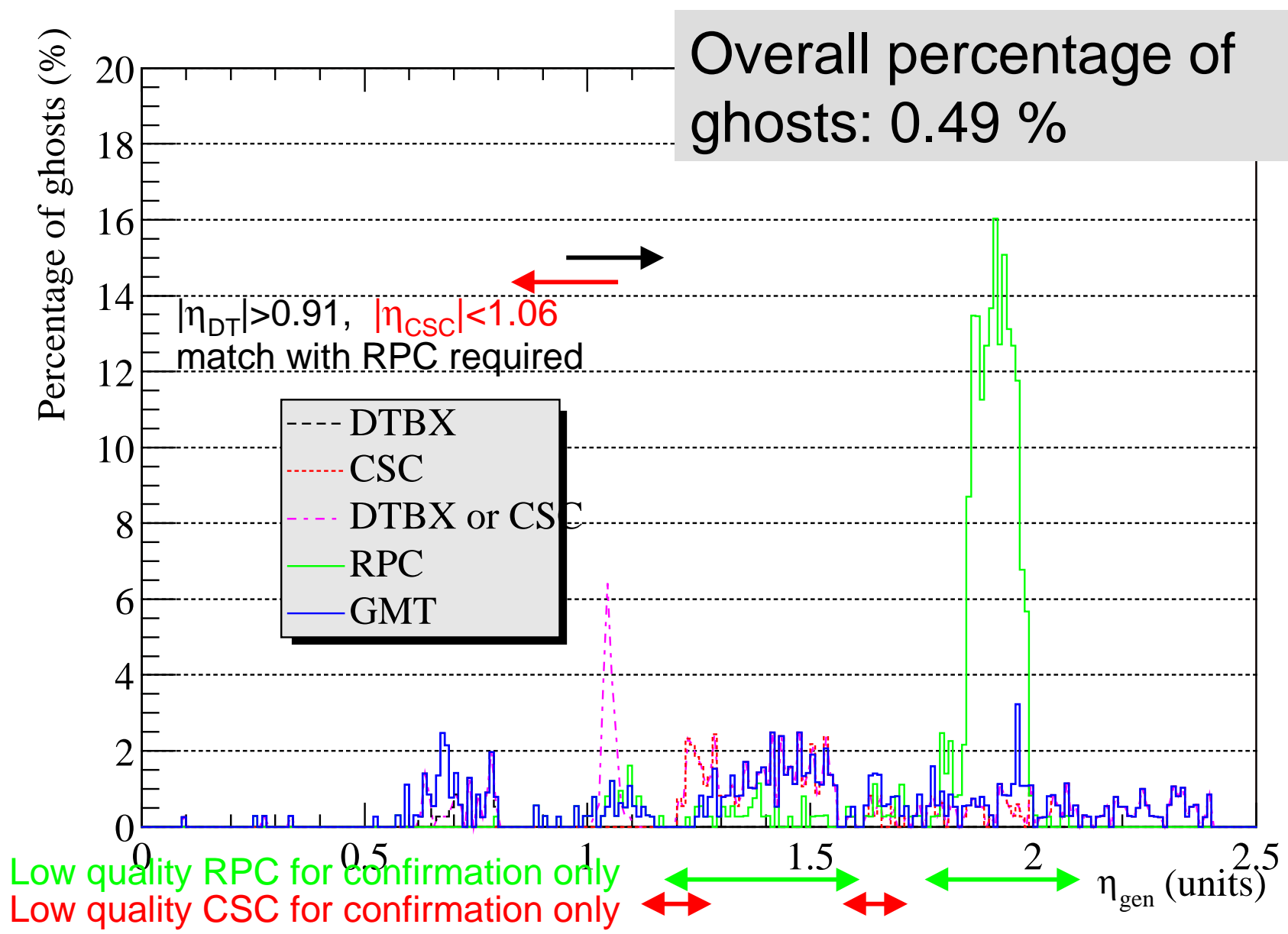



Efficiency vs. ϕ , barrel (ORCA 4)

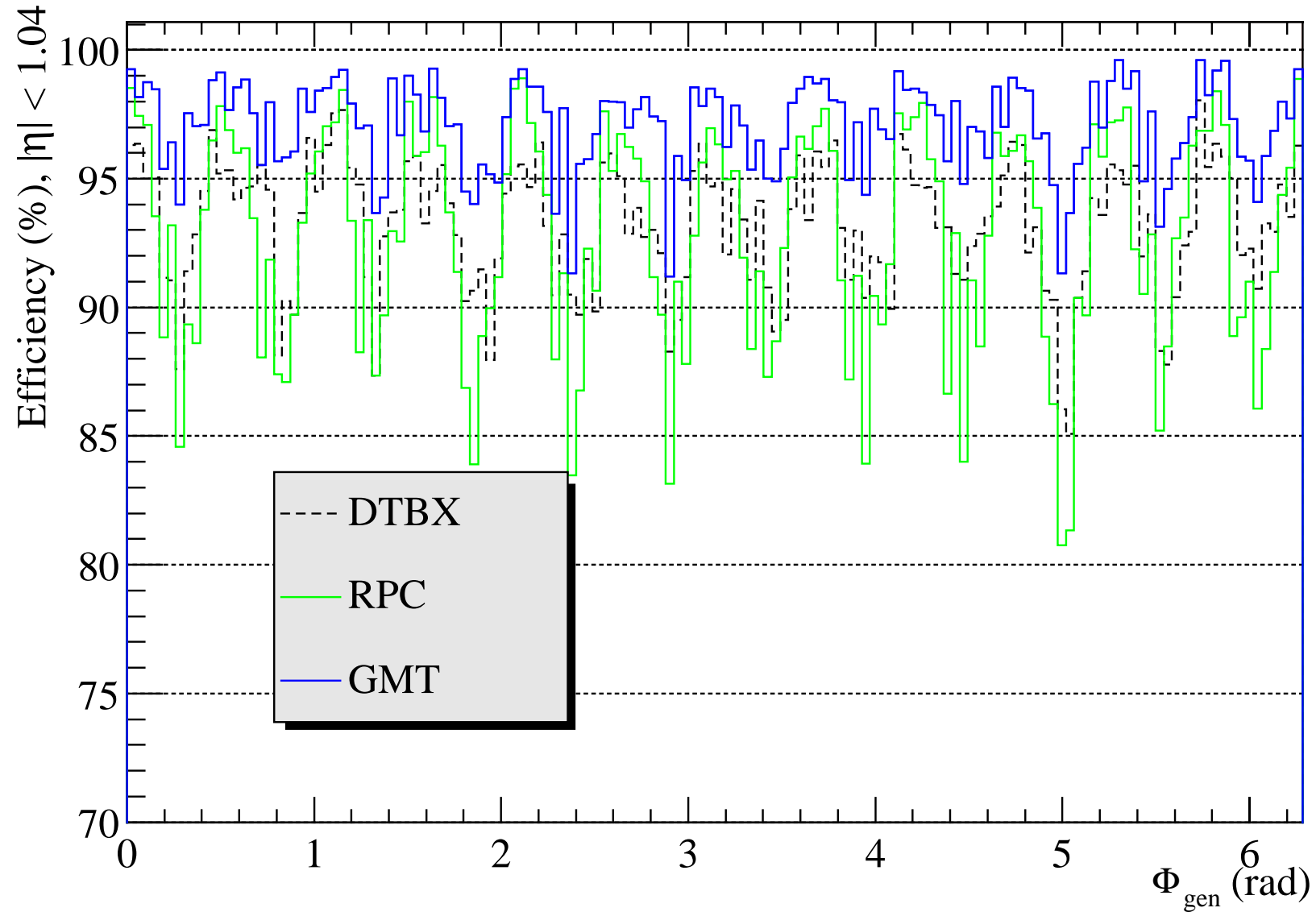



Efficiency vs. ϕ , endcap (ORCA 4)

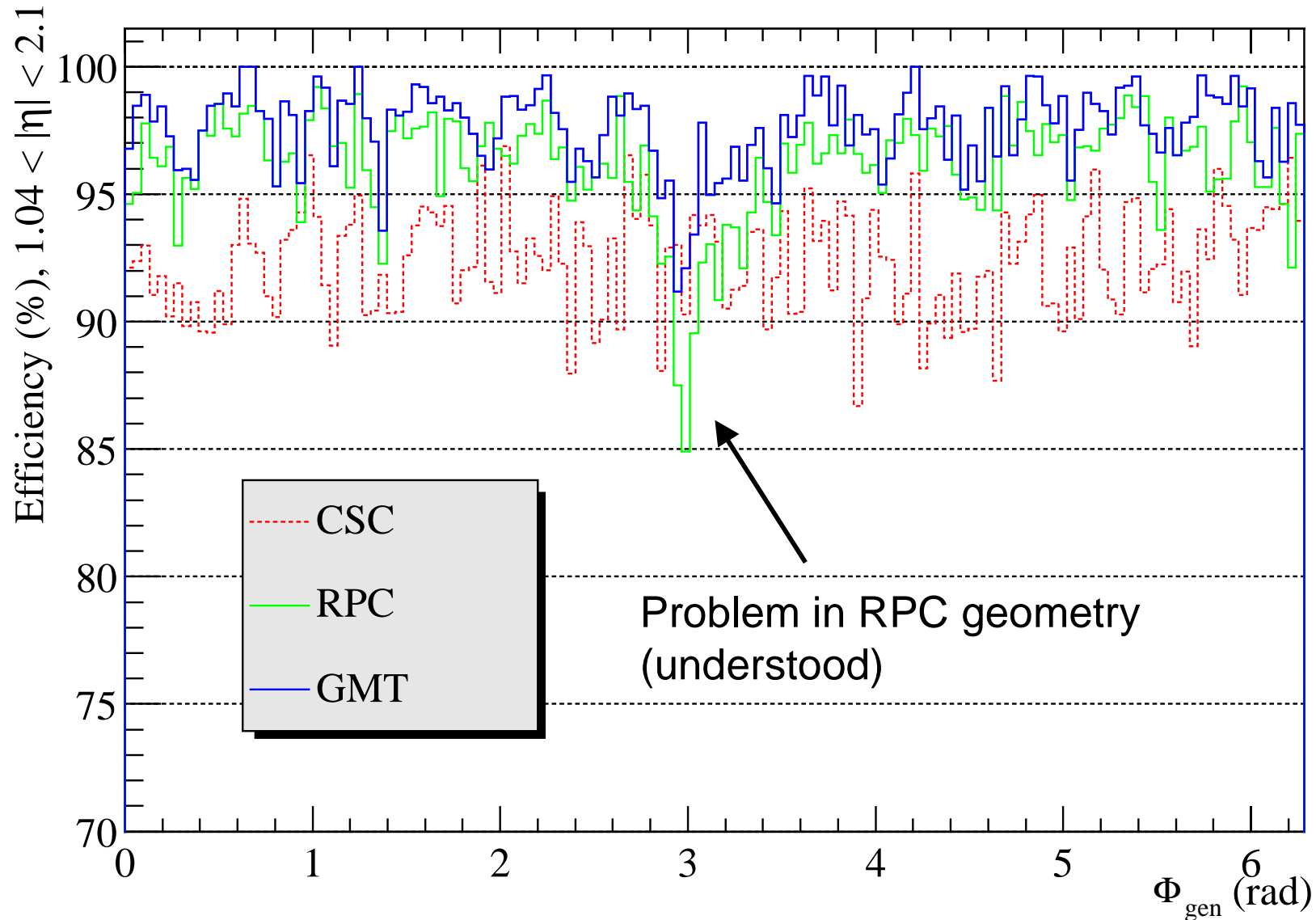



Efficiency vs. p_T , barrel (ORCA 4)

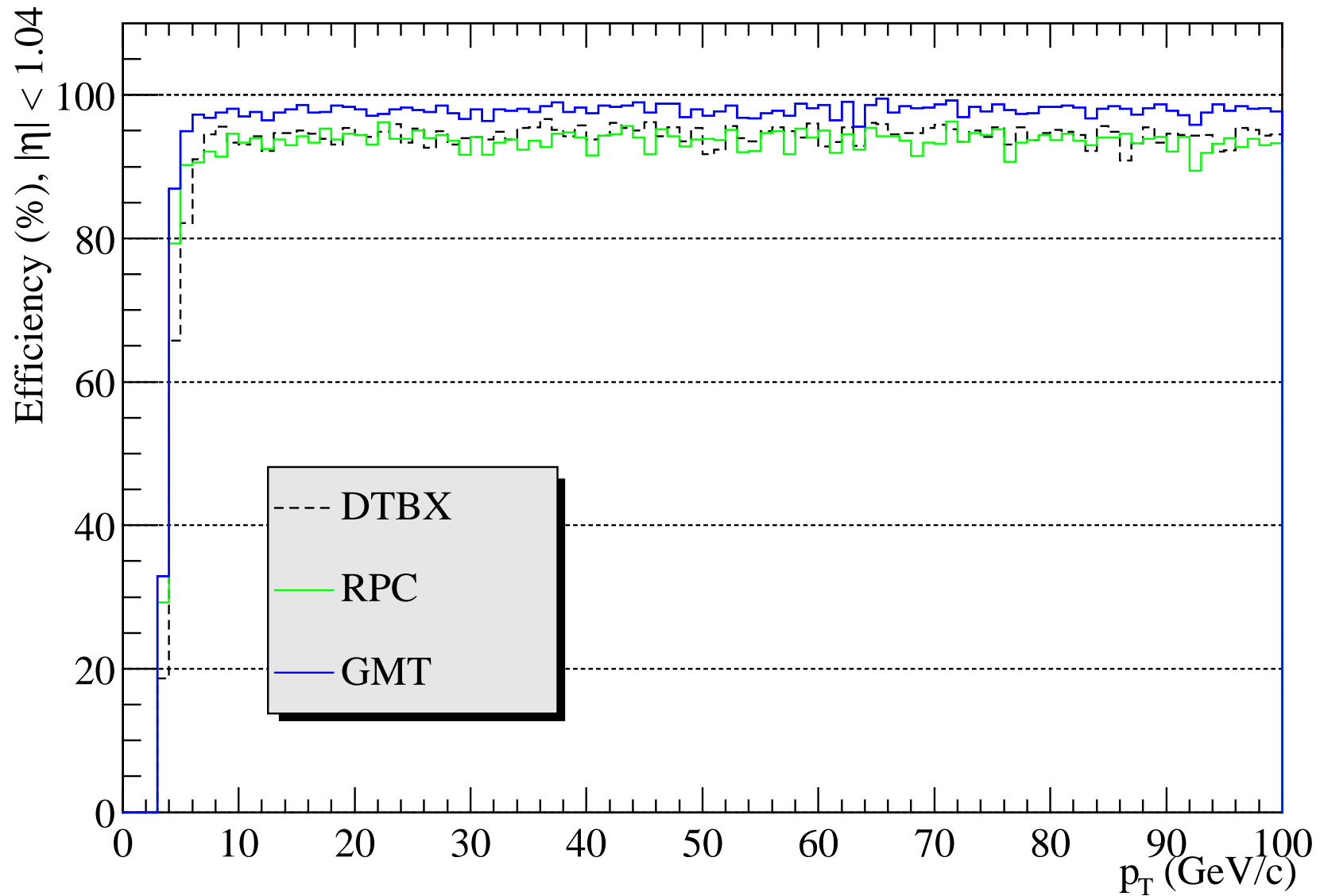

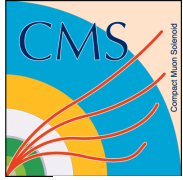

Efficiency vs. p_T , endcap (ORCA 4)

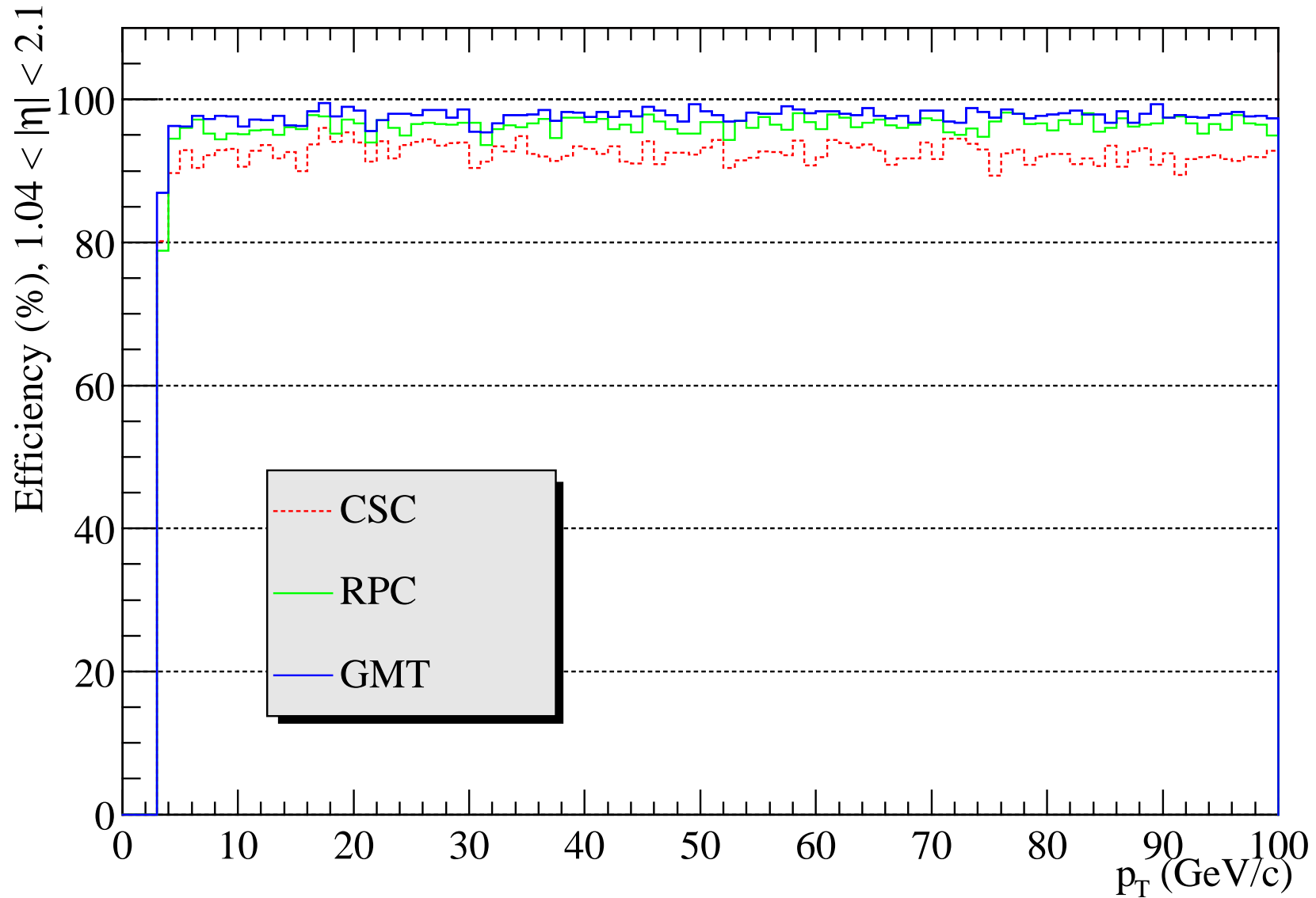



Efficiencies (single muons)



- **Barrel** $0 < |\eta| < 0.8$

	No muon found	one muon found	two muons found
RPC	7.03 ± 0.15 %	92.96 ± 0.15 %	0.01 ± 0.01 %
DT	3.88 ± 0.11 %	95.96 ± 0.11 %	0.14 ± 0.02 %
GMT	2.01 ± 0.08 %	97.72 ± 0.09 %	0.26 ± 0.03 %

- **Endcap** $1.2 < |\eta| < 2.1$

	No muon found	one muon found	two muons found
RPC	3.23 ± 0.10 %	94.61 ± 0.12 %	2.15 ± 0.08 %
CSC	5.48 ± 0.13 %	93.74 ± 0.13 %	0.77 ± 0.05 %
GMT	1.53 ± 0.07 %	97.64 ± 0.08 %	0.82 ± 0.05 %

- **Overall** $-2.4 < \eta < 2.4$

	No muon found	one muon found	two muons found
GMT	3.34 ± 0.06 %	96.17 ± 0.06 %	0.49 ± 0.02 %

Global Muon Trigger



p_T -resolution



DTBX

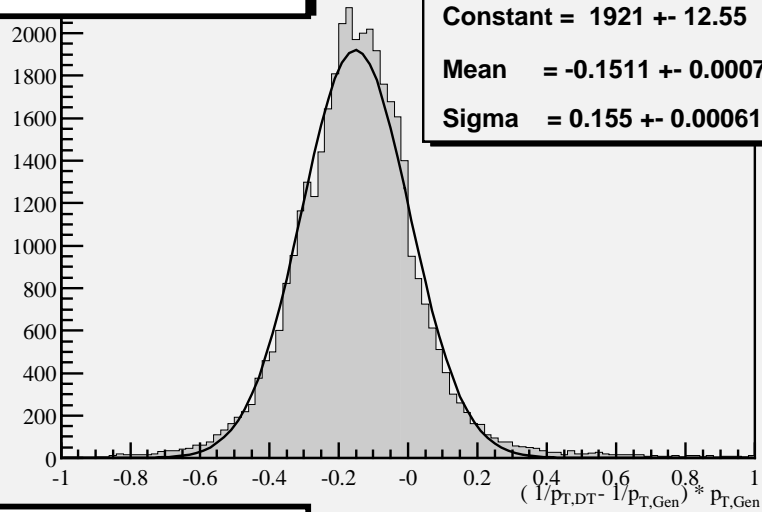

Chi2 / ndf = 1224 / 95
Constant = 1921 +/- 12.55
Mean = -0.1511 +/- 0.0007161
Sigma = 0.155 +/- 0.000617

Results for barrel only

$|\eta| < 1.04$

center of curves shifted
due to 90% p_T -definition

RPC

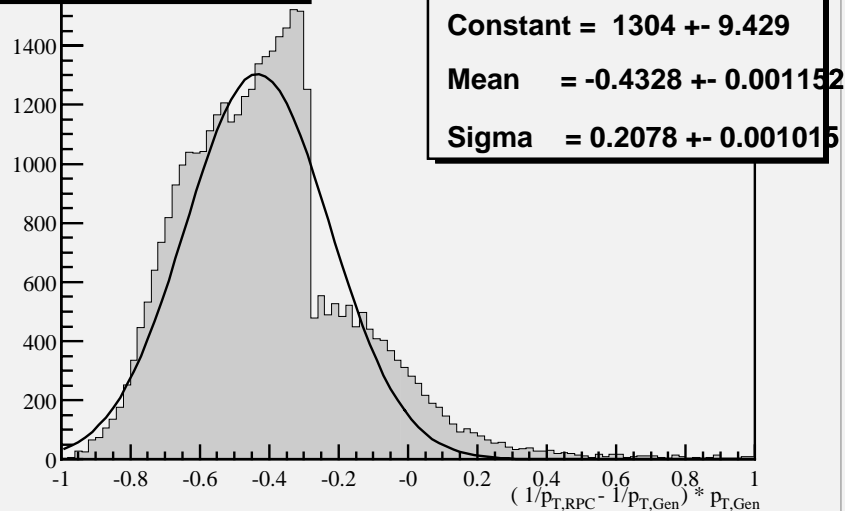

Chi2 / ndf = 3884 / 96
Constant = 1304 +/- 9.429
Mean = -0.4328 +/- 0.001152
Sigma = 0.2078 +/- 0.001015

GMT

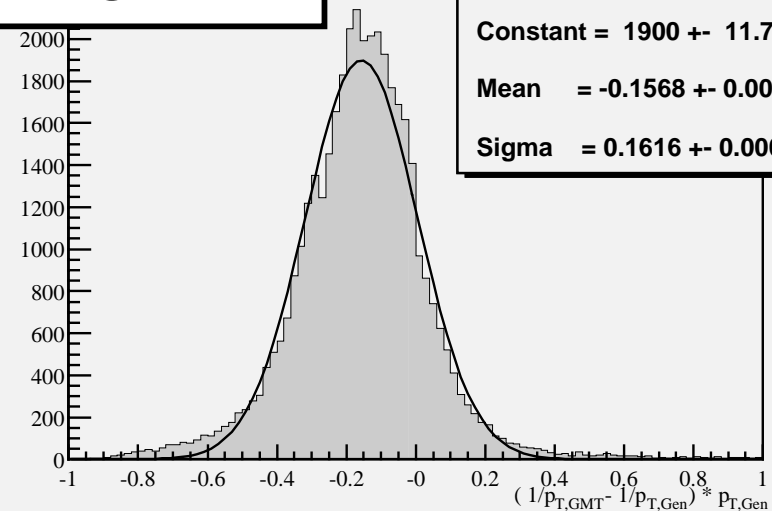

Chi2 / ndf = 1679 / 96
Constant = 1900 +/- 11.7
Mean = -0.1568 +/- 0.0007483
Sigma = 0.1616 +/- 0.000559

Turn-on curves

DTBX

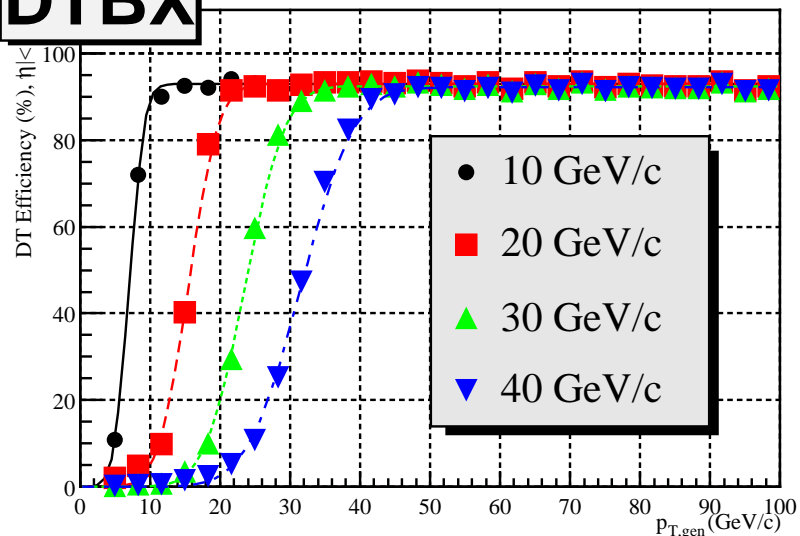

Results for barrel only
 $|\eta| < 1.04$

p_T definition now at 90%

RPC

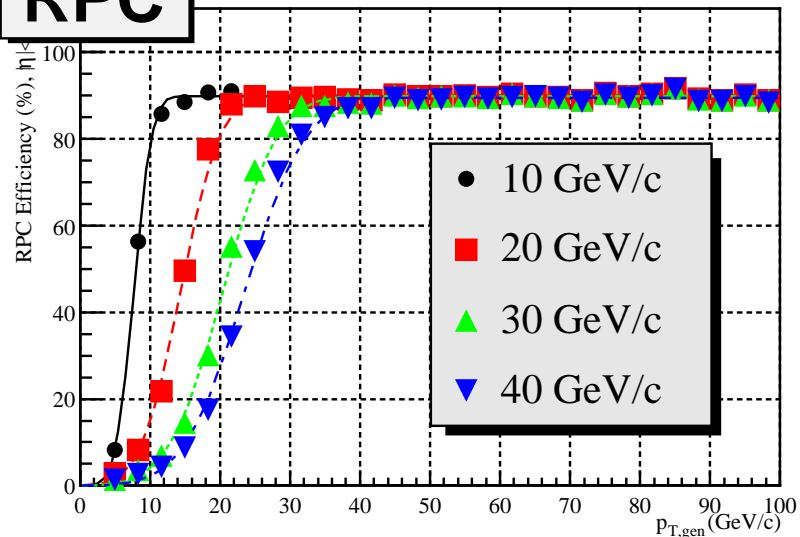

GMT

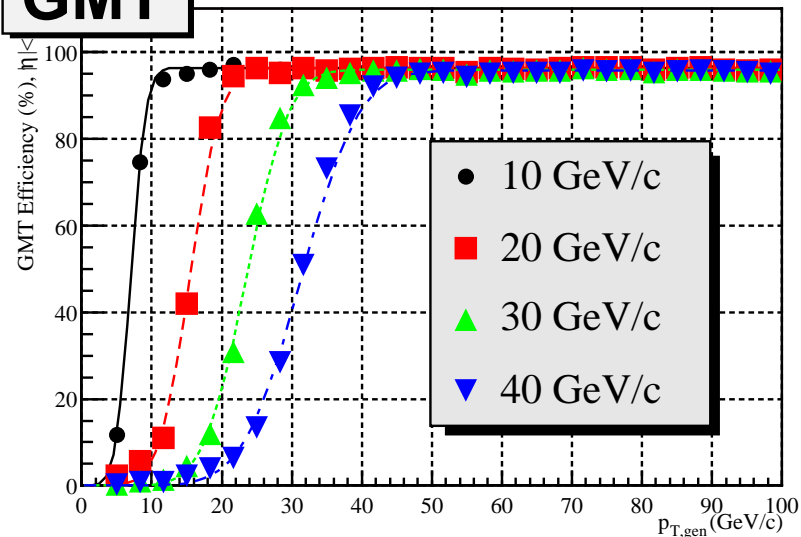

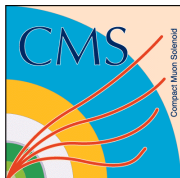

Conclusion



- Muon merger logic foreseen in hardware
- Agreement on common p_T scale and 90%- p_T definition in all systems
- Whole detector now simulated in ORCA4
- Preliminary Simulation Results shown
 - GMT improves efficiency
 - GMT reduces duplication (“ghosts”) (also in overlap region)



Plans



- Detailed simulation study of trigger rates (single and di-muon) and optimization of GMT look-up-tables for optimum rate
 - requires ORCA 4.3.0 release with updated CSC trigger & track finder code
 - requires re-processing of July HLT samples
 - important in order to get TDR plots
- Finish conceptual GMT design