

On-line Software Requirements for the Global Trigger, the Global Muon Trigger and the Barrel Muon Trigger Track Finder



Claudia-Elisabeth Wulz
&
HEPHY Vienna Trigger Group

CERN, 29 Sept. 2001



General considerations for software

On-line SW required at all instances of L1 trigger construction, commissioning and operation. Development and prototyping phase: e.g. VHDL, AHDL, CVS, LabView, ... Testing and quality assurance for series production and later synchronization, setup and monitoring of final modules will need additional SW, ideally within a CMS framework.

Key requirements:

- **Common user interface**
- **Vertical structure with different functionalities and authorization levels**
- **Modularity**
- **Maintainability**
- **Platform independence (as far as possible)**
- **Worldwide access**



Software tasks

The following tasks must be performed by all trigger systems:

- **Setup**
- **Testing**
- **Operation**
- **Recording**
- **Monitoring**
- **Trouble-shooting**
- **Upgrading (later)**

A single user interface should allow control of these functions, which are performed either **centrally or **locally** (or both, but with proper arbitration).**

Central: Within CMS - Run control, DAQ

Local: Within subsystem



Setup

Setup consists of:

- **Loading parameters (including logic configuration)**
- **Synchronization (not covered in this talk)**
N.B. Initialization belongs to “Operation”.

Parameters:

External and internal parameters

Internal parameters:

**Included in these are logic configurations of FPGA's and LUT's.
Rarely changed, e.g. for different physics periods (discovery, B).
Typically only changed by experts, within Local Control.**

External parameters:

**Run parameters, e.g. trigger table. Set by normal shift personnel.
Included is also list of channels to be treated specially. Run
Control manages database for the parameters.**



Testing

Periodic standard tests invoked automatically (e.g. at power on, at start of run, at defined bx within orbit):

System completeness (e.g. boundary scan)

Basic functionality (e.g. test data injection)

Software compatibility

Tests on demand:

Specific test procedures, either within system or outside, e.g. after installation of new modules

N.B. This does not include trouble-shooting procedures.



Operation

Operation includes procedures to start, stop or interrupt a run, either in local or in central mode. Starting a run or resuming running after a general synchronization request implies initialization of certain registers and counters. At the start of a run all counters and registers are set to their defined start values. A priority protocol has to be established between local and central control.



Recording

Recording means writing data to a “permanent” storage medium. It is controlled either by the central DAQ or the local acquisition. At every change of run conditions an entry to the data base with the relevant parameters (external parameters, DCS parameters etc.) should be made. The actual trigger data record is prepared in the appropriate boards of each trigger subsystem. The central DAQ records the record. Optionally a set of “history data” (events $-n, -n+1, \dots, -1, 1, \dots, n$) can also be recorded. Besides the central DAQ, a local DAQ can also record the event data. In addition, it should be able to record values of internal registers, histories of issued commands etc.



Monitoring

Monitoring should be automatically invoked for each run. It should run both centrally and locally. Central monitoring should include checks on data available only outside the L1 trigger system (e.g. L2 and HLT data, tracker data).

Monitoring should include event-to-event based checks, time integrated checks and should also enable to read back the internal and external parameters at regular intervals.

The monitoring program should be able to recognize faults and to initiate appropriate actions, whether automatic or manual. It could also foresee automatic calibration procedures with subsequent recalculation and reloading of parameters (but this may be dangerous...).

Monitoring events can be requested by the central or the local DAQ.



Trouble-shooting

The necessity for trouble-shooting can be established automatically (initiated by the monitoring program or after failed self-test procedures) or manually (initiated by a physicist).

Each electronic module must have specific trouble-shooting software, to be used either within the system or in isolation in the laboratory.

Details of fault tolerance have to be established by each trigger subsystem.



GT and GMT Hardware

- **Global Trigger (1 main rack, 1 auxiliary rack)**
 - **Main 9U-crate in main rack: PSB (3), GTL (1), FDL (1), GTFE (1), TCS (1), TIM (1), L1A (1)**
 - **2 6U-crates: fast signal reception, tracker emulator, private monitoring and test boards**
 - **Auxiliary rack: subsystem specific modules**
 - **The main rack contains 3 CPU's for monitoring, DAQ and local/private tasks.**
- **Global Muon Trigger (modules housed in GT main 9U-crate)**
 - **PSB (3), GTMU (1) across 4 slots due to 16 input connectors**
 - **Any processing for the GMT is done within the GT framework**



Main GT/GMT 9U-Crate

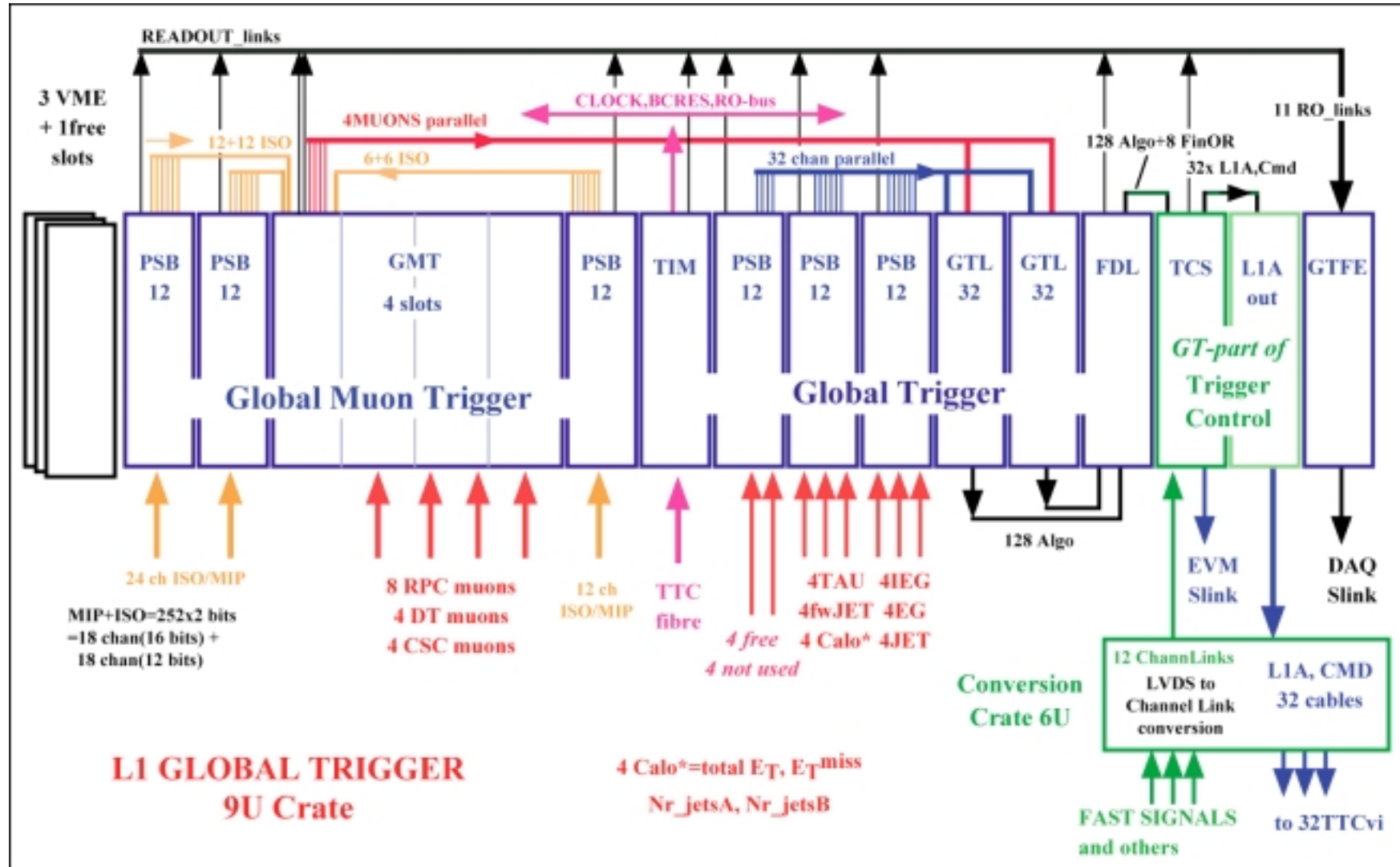

A. Taurok Sept 01



Main GT Rack

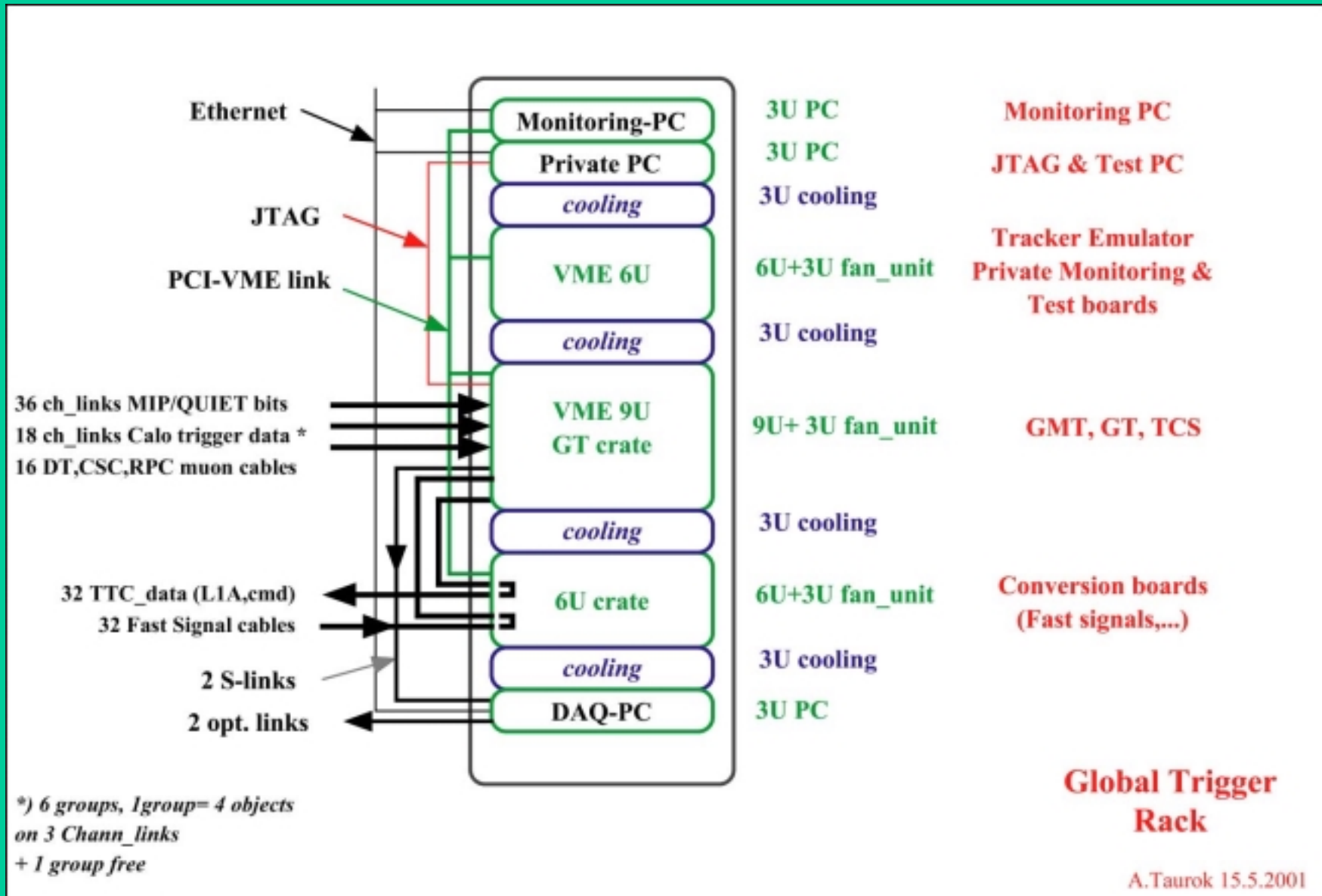



Global Trigger Software - Setup

Setup

External parameters:

Mask for 128 algorithm bits

Mask for 8 final OR bits

Orbit protocol

Trigger rules for TCS

Thresholds(N.B. topology preset within algorithm logic)

128 prescale factors

List of disabled channels

Recording options (standard mode, debug mode etc.)

Mode selection (real data, simulated data)

Normal running: External parameters set by Run Control.

Alternative: External parameters set by Local Control. Protocol between the two has to be established!



Global Trigger Software - Setup and Testing

Setup

Internal parameters:

Logic configuration for the Algo AND/OR chips and condition chips

Error conditions

Synchronization parameters:

PSB: phase checks, parity checks, delays etc.

Normal running: Internal and synchronization parameters preset.

Alternative: Internal parameters set by Local Control.

Testing

Boundary scan and other JTAG tests

Tests with simulated data

DCS checks

Status checks (e.g. presence of calo/muon)



Global Trigger Software - Operation

Operation

Operation of the Global Trigger will be controlled with the user interface.

Initialization

Different levels. Start of new run: all registers and counters set to their predefined start values. At a reset during a run, only certain values will be reset.

Initial values:

Bunch counter: 0 (reset at every orbit)

Orbit counter: 0 (at start of run)

Event counter: 0 (at start of run)

8 L1A counters: 0 (reset every second?)

128 algorithm counters: 0 (reset every second?)

Error counters: 0 (at start of run or at defined intervals)



Global Trigger Software - Recording

Recording

The GT event record prepared in the GTFE board will be transferred to DAQ, like for any other subdetector. Control data for the EVM (L1A and event nr. for each partition group, possibly trigger type) will be sent on a separate S-link.

Event record

Event nr., orbit nr., bx nr., GPS time

All input bits (calo/muon)

8 final OR bits

128 algorithm bits



Global Trigger Software - Initial values

Initial values:

Bunch counter: 0 (reset at every orbit)

Orbit counter: 0 (at start of run)

Event counter: 0 (at start of run)

8 L1A counters: 0 (reset every second?)

128 algorithm counters: 0 (reset every second?)

Error counters: 0 (at start of run and at defined intervals)



Global Trigger Software - Monitoring

Monitoring

Status

Data throughput (input of PSB's, output of algos on GTL)

DCS information (presence of partitions, menu settings, ...)

Performance

Collision rate

L1A rate

Rates for each of the 128 algos

Error rates for each error condition

Dead times and live times (rates of rejected L1A's due to trigger rules etc.)

Physics (examples)

η , ϕ , p_T and E_T distributions of trigger objects

Comparisons with HLT and recorded data

Efficiencies



Global Muon Trigger Software - Setup

Setup

External parameters

Active systems (DT, CSC, RPC)

Internal parameters

Logic FPGA (barrel, forward)

η conversion LUT DT/CSC, η conversion LUT RPC

rank η quality LUT's, rank p_T quality LUT's, rank $\eta \phi$ LUT's, ...

matcher $\Delta\eta$ LUT, matcher match quality LUT

cancel-out unit $\Delta\eta$ LUT, cancel-out unit match quality LUT,

cancel-out unit cancel decision LUT

charge assignment LUT

merger LUT's

MIP & ISO assignment FPGA (2x)

ϕ projection LUT

ϕ region select LUT

η projection region selection LUT

Synchronization parameters



Global Muon Trigger Software

Normal running: Internal parameters are preset, no action from Run Control necessary.

Alternative: Configuration is changed locally (only via LUT's).

Testing

Similar to Global Trigger. Test patterns from ORCA.

Operation

Automatically integrated in Global Trigger operation for central mode. In local mode the GMT must run also independently of Global Trigger. Initialization not required.



Global Muon Trigger Software

Monitoring

Status

similar to Global Trigger (data throughput, DCS parameters)

Performance

Matching efficiencies between active muon systems

Ranking

Isolation and MIP bit assignment

Ghosts

Physics

η , ϕ , p_T and E_T distributions of muon candidates in and out

Comparison with reconstructed muons

Trigger efficiencies

Recording

There is no separate data record (yet...), included in GT.



Barrel Muon Trigger Track Finder Hardware

- **Drift Tube Trigger Track Finder DTTF (2 racks)**
 - Sector Processors (48 boards standard, 2x12 DT/CSC overlap region)
- **Eta Track Finder ETF (in same racks as above)**
 - 12 Eta Assignment Units (1 board per wedge)
- **Sorters**
 - 12 Wedge Sorters (1 board per wedge, in same racks as above)
 - Barrel Sorter (1 board, location still undecided)



Barrel Muon Trigger Track Finder Crate

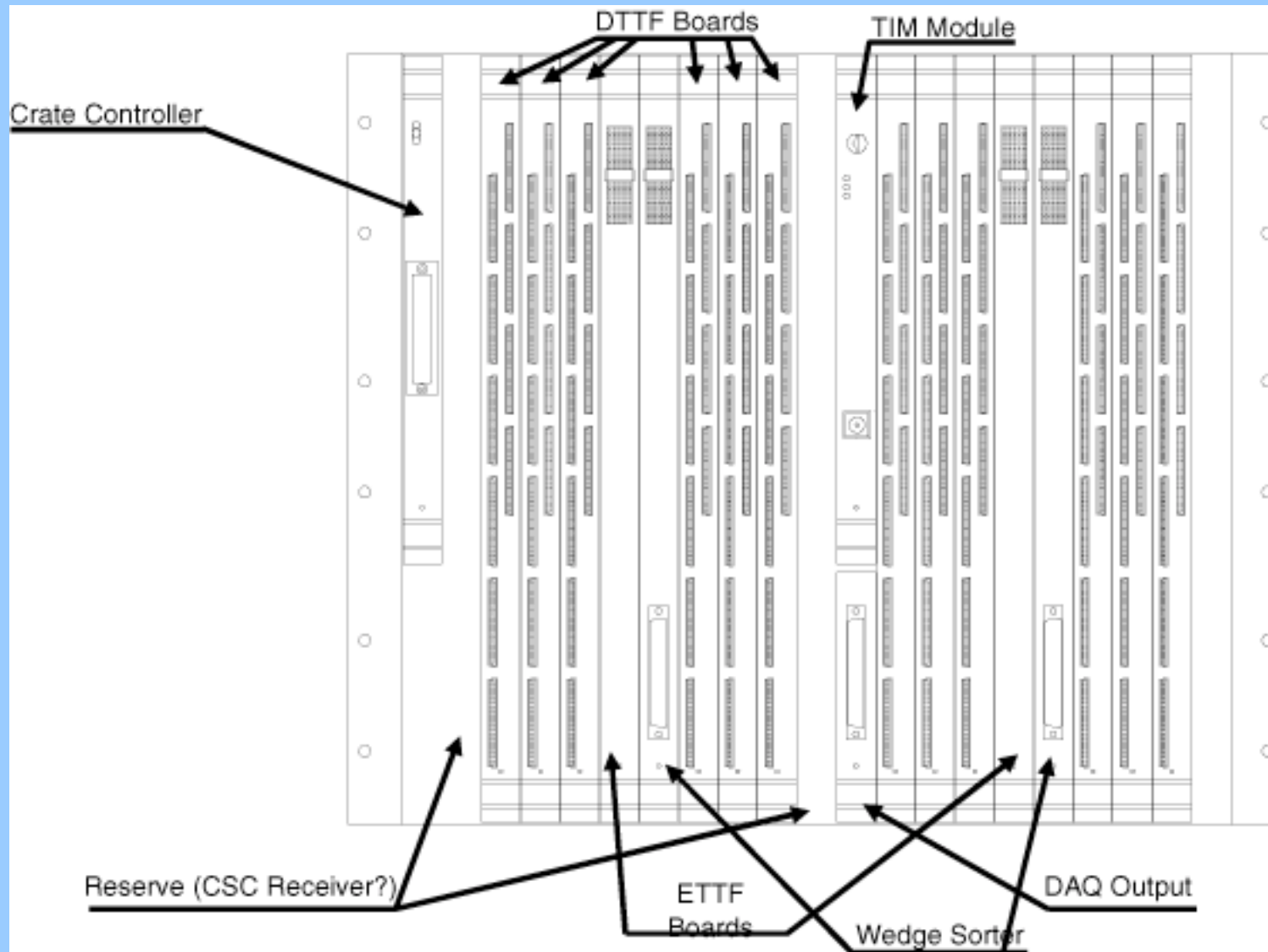

J. Erö



Barrel Muon Trigger Track Finder Racks

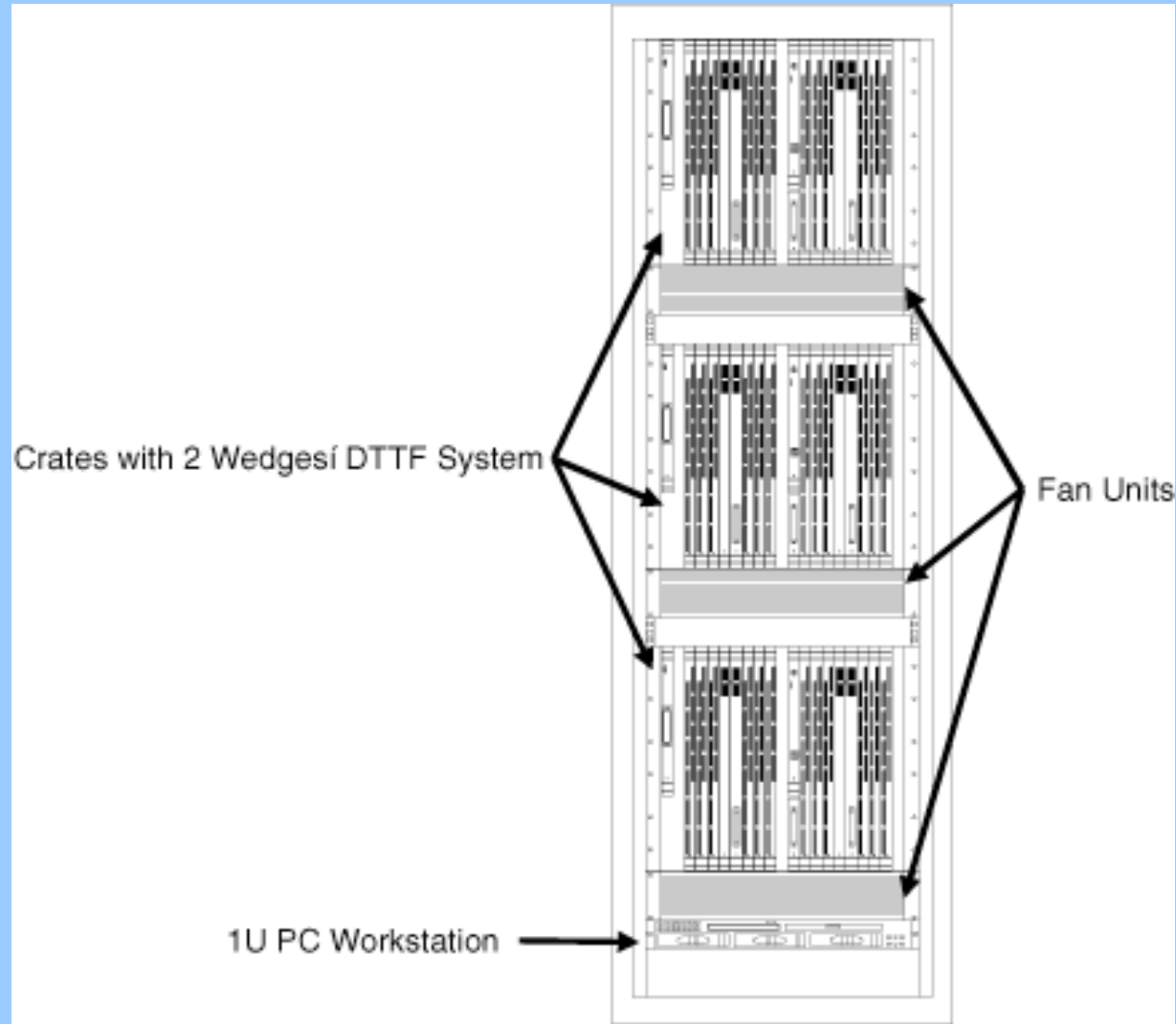

J. Erö



Barrel Muon Trigger TF Software

Setup

External parameters

Mode selection bits (e.g. include 2->1 extrapolations)

Disabled components

Internal parameters

Extrapolation LUT's

Assignment LUT's

Synchronization parameters

Not necessary for central running, all should be preset.

Normal mode: Everything is preset.

Alternative: Change LUT's in local mode.



Barrel Muon Trigger TF Software

Testing

Similar to Global Trigger for JTAG and DCS. Test patterns from ORCA. Test pulses in DT chambers.

Operating

In central mode no user action necessary except setting of external parameters (few). TF can be operated standalone in local mode, also with simulated data.

Initialization

Reset bx counter on BC0.



Barrel Muon Trigger TF Software

Recording

Header

From each DTTF board:

- 110 bit from DT optical link
- 180 bit extrapolation result tables
- 30 bit addresses of found tracks
- 10 bit coded track addresses to ETF
- 8 bit track category used in assignment
- 34 bit DTTF output

From each ETF board:

- 240 bit optical input from DT θ -layers
- 110 bit qualified pattern
- 60 bit coded track addresses from DTTF
- 72 ETF output



Barrel Muon Trigger TF Software

Monitoring

Status

similar to Global Trigger (data throughput, DCS parameters)

Performance

Sector processor output (track candidates and their qualities)

Eta assignment quality

etc.

Physics

η , ϕ , p_T and E_T distributions of muon track candidates

Comparison with reconstructed muons

Trigger efficiencies